

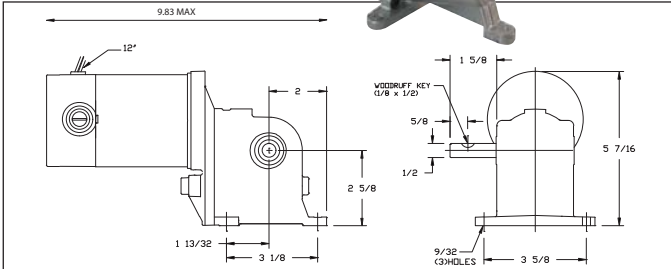

1LRA8



90VDC Permanent-Magnet Right-Angle Gearmotors



- Enclosure: totally enclosed nonventilated
- Gearcase: die-cast zinc
- Lubrication: grease packed
- Gears: input gear steel; worm hardened steel; output gear cast iron
- Bearings: bronze sleeve on case, ball on motor
- Mounting: all-position, base
- Rotation: reversible
- Brushes: externally replaceable
- Ambient: 40°C
- Seals: on output shaft
- Gear limited
- Units are compatible with speed control 2PUX3 (sold separately on Grainger.com)

Nameplate RPM	Max. Torque	Overhung Load	Input HP	Gear Ratio	Full Load Amps	Item No.
3 RPM	250 in-lb	100 lb	1/20	525:1	0.59 A	1LRA8
6 RPM	177 in-lb	100 lb	1/20	275:1	0.59 A	1LRA9
10 RPM	228 in-lb	100 lb	1/20	161:1	0.59 A	1LRB1
24 RPM	102 in-lb	100 lb	1/20	70:1	0.59 A	1LRB2
45 RPM	56 in-lb	100 lb	1/20	37:1	0.59 A	1LRB4
90 RPM	34 in-lb	100 lb	1/10	37:1	1.14 A	1LRB3
Replacement Motor Brush Set						6YHY6

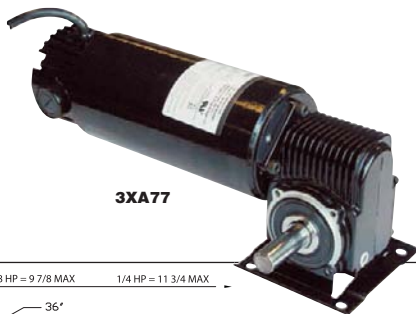

3XA77

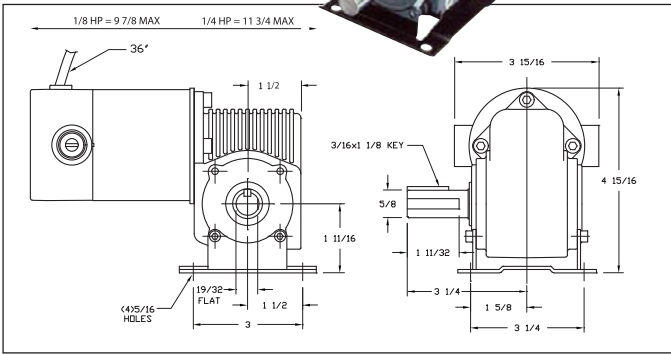

90VDC Permanent-Magnet Hollow-Shaft Right-Angle Gearmotors



- Enclosure: totally enclosed nonventilated
- Gearcase: die-cast aluminum
- Lubrication: permanent, heavy fluid gear oil
- Gears: worm-hardened steel, output gear bronze alloy
- Bearings: ball on output and motor
- Mounting: all-position, base
- Rotation: reversible
- Brushes: externally replaceable
- Ambient: 40°C
- Reversible shaft output
- Seals: lip-type on input and output shafts
- 1/8-HP units accept direct motor-mount speed control 2PUX3 (sold separately on Grainger.com)
- Accept pulse generator 6Z392 or 5J165 (sold separately on Grainger.com)

Nameplate RPM	Max. Torque	Overhung Load	Input HP	Gear Ratio	Full Load Amps	Item No.
30 RPM	94 in-lb	175 lb	1/8	60:1	1.28 A	3XA82
40 RPM	82 in-lb	175 lb	1/8	45:1	1.28 A	3XA81
60 RPM	60 in-lb	175 lb	1/8	30:1	1.28 A	3XA80
	120 in-lb	175 lb	1/4	30:1	2.33 A	3XA86
90 RPM	49 in-lb	175 lb	1/8	20:1	1.28 A	3XA79
	100 in-lb	175 lb	1/4	20:1	2.33 A	3XA85
180 RPM	27 in-lb	175 lb	1/8	10:1	1.28 A	3XA78
	55 in-lb	175 lb	1/4	10:1	2.33 A	3XA84
360 RPM	14 in-lb	175 lb	1/8	5:1	1.28 A	3XA77
	30 in-lb	175 lb	1/4	5:1	2.33 A	3XA83
Replacement Motor Brush Set						6YHY6

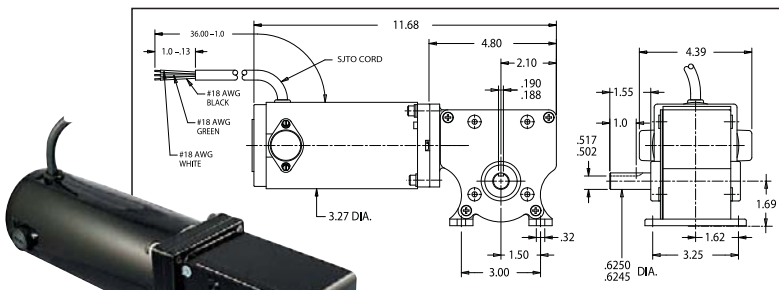

5LAE8

12, 24, and 90VDC Right-Angle Gearmotors



- Enclosure: totally enclosed nonventilated
- Gearcase: die-cast zinc
- Lubrication: heavy gear oil
- Gears: metal
- Bearings: needle roller
- Mounting: all-position
- Rotation: reversible
- Brushes: externally replaceable
- Ambient: 40°C
- Seals: lip-type on input and output shafts

Description	For Use With	Item No.
Motor Brush Set		
12 and 24VDC Motor Brush Set	5LAF4 thru 5LAF9, 5LAG0 thru 5LAG5	33K907
90VDC Motor Brush Set	5LAE8, 5LAE9, 5LAF0 thru 5LAF3	33K906

Max. Torque	Overhung Load	Input HP	Gear Ratio	Length Less Shaft	12V DC Full Load			GEARMOTOR VOLTAGE 24V DC Full Load			90V DC Full Load		
					Nameplate RPM	Load Amps	Item No.	Nameplate RPM	Load Amps	Item No.	Nameplate RPM	Load Amps	Item No.
280 in-lb	175 lb	1/8	82:1	11 3/4 in	20 RPM	10.4 A	5LAF4	20 RPM	5.2 A	5LAG0	22 RPM	1.41 A	5LAE8
266 in-lb	175 lb	1/8	60:1	11 3/4 in	—	—	—	26 RPM	6.3 A	5LAG1	30 RPM	1.72 A	5LAE9
196 in-lb	175 lb	1/8	44:1	11 3/4 in	—	—	—	36 RPM	6.3 A	5LAG2	40 RPM	1.72 A	5LAF0
165 in-lb	175 lb	1/8	28:1	11 3/4 in	54 RPM	16 A	5LAF7	54 RPM	8 A	5LAG3	—	—	—
123 in-lb	175 lb	1/8	28:1	11 3/4 in	—	—	—	—	—	—	64 RPM	1.72 A	5LAF1
137 in-lb	175 lb	1/8	23:1	11 3/4 in	—	—	—	65 RPM	8 A	5LAG4	—	—	—
103 in-lb	175 lb	1/8	23:1	11 3/4 in	—	—	—	—	—	—	77 RPM	1.73 A	5LAF2
63 in-lb	175 lb	1/8	10:1	11 3/4 in	150 RPM	16 A	5LAF9	150 RPM	8 A	5LAG5	—	—	—
47 in-lb	175 lb	1/8	10:1	11 3/4 in	—	—	—	—	—	—	177 RPM	2.01 A	5LAF3