

MATLOCK Folding Aluminium Handy Steps

Strong & sturdy folding aluminum steps. Large (405W x 242D mm) durable platform for safe & comfortable standing. Ideal for use in many environments.

Load capacity: 150kg.
Comply to **EN-14183**.



Model Number	No. of Treads	Weight each	Order Code	Price/1 THB
FS253Z	2	3.0kg	-2020K	4326.00
FS369Z	3	4.0kg	-2030K	5817.00

KENNEDY Folding Mobile Crane

Ideal for home workshops or garages. Folding design for easy storage and transportation. Flow control valve for precise lowering and positioning. Overload safety valve. Hydraulic operation providing easy lifting. Heavy duty swivel hook with safety latch. Four different jib options. Heavy duty castors.

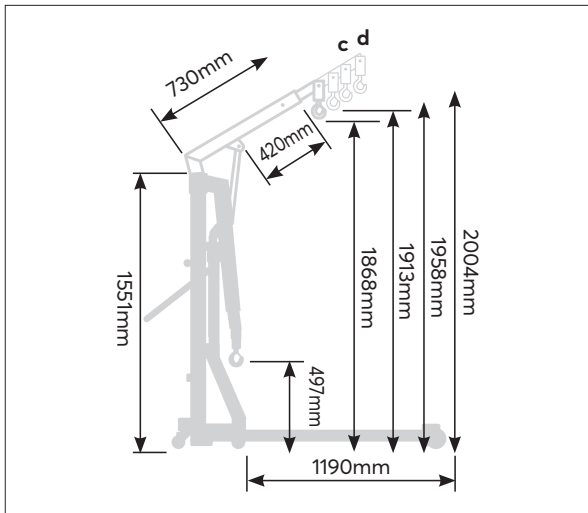

Model number.....	FMC001.
Order Code	KEN- 985- 3670K.
Lifting capacity position (a)	1,000kg.
Lifting capacity position (b)	750kg.
Lifting capacity position (c)	500kg.
Lifting capacity position (d)	250kg.
Maximum lifting height at minimum jib extension.	1868mm.
Maximum lifting height at maximum jib extension.	2004mm.
Length of jib in position (a)	865mm.
Length of jib in position (b)	955mm.
Length of jib in position (c)	1045mm.
Length of jib in position (d)	1135mm.
Clearance height of legs	130mm.

1 tonne (metric ton or t) = 1000kg
1 ton (imperial ton) = 2240lbs (1016kg)

Length of frame	1480mm.
Overall clearance height	1555mm.
Maximum width of frame	1000mm.
Distance between rear wheel centres	640mm.
Weight	91kg.

Model Number	Capacity	Max Hook Height (mm)	Weight each	Order Code	Price/1 THB
FMC001	1 Tonne	2004	91kg	-3670K	59850.00