



Dial Indicating Torque Wrenches

Ideal for use in inspection and quality control, research and development, production and after sales service. Lightweight aluminium handles, abrasive resistant bodies for longer life and easy read dual scale for observing the amount of torque applied throughout the tightening process. Socket not included. Manufactured to ISO 6789-2:2017. (Accuracy ±4% of reading).

1/4" Square Drive Not suitable for use with extensions.



Product Number	Torque Range		Weight each	Order Code KEN-555	Price/1 THB
	Nm	lbf.in			
TW4	0.8 - 4.0	7 - 35	520g	-1040K	23100.00
TW8	1.6-8	14-75lbf.in	520g	-1060K	23321.00
TW12	2.4 - 12	24 - 120	520g	-1120K	23678.00

3/8" Square Drive (not illustrated)

Product Number	Torque Range		Weight each	Order Code KEN-555	Price/1 THB
	Nm	lbf.in			
SW25	5 - 25	48 - 240	520g	-1250K	21704.00
SW40	8 - 40	72 - 360	520g	-1400K	25694.00

Product Number	Torque Range		Weight each	Order Code KEN-555	Price/1 THB
	Nm	lbf.ft			
MW80	16-80	12-60	1.35kg	-2140K	34598.00

3/4" Square Drive
With built-in audio/visual signal.



1/2" Square Drive



Product Number	Torque Range		Weight each	Order Code KEN-555	Price/1 THB
	Nm	lbf.ft			
MW80	16-80	12-60	1.35kg	-2080K	46305.00
MW100	32-160	24-120	1.41kg	-2160K	34839.00
MW160	20-100	14-70	1.41kg	-2180K	35154.00
MW200	40 - 200	30 - 160	1.40kg	-2200K	35511.00

Product Number	Torque Range		Weight each	Order Code KEN-555	Price/1 THB
	Nm	lbf.ft			
LW800	160 - 800	120 - 660	4.85kg	-3800K	66287.00
MW400	80-400	60-300	3.2kg	-2300K	56469.00

KENNEDY Torque Multipliers

Ideal for applications where no electrical or air supply is available. Enables precision tightening of threaded fasteners. Aids the loosening of nuts that are corroded or seized. Accurate to within ±4%, taking the uncertainty out of high torque tightening.

TN14: Input: 1/2" sq. drive. **Output:** 3/4" sq. drive.

TN27: Input: 3/4" sq. drive. **Output:** 1" sq. drive.

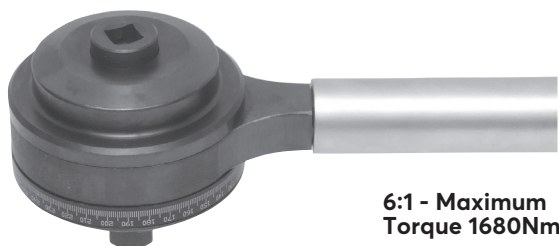

6:1 - Maximum Torque 1680Nm

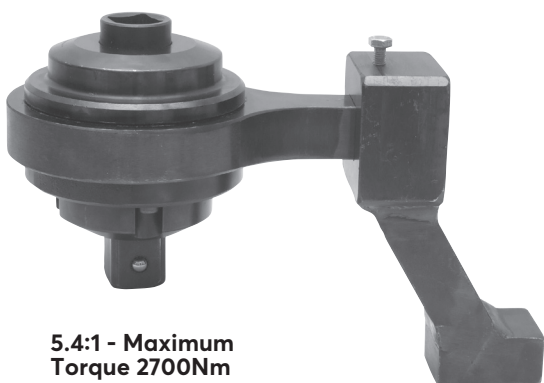

5.4:1 - Maximum Torque 2700Nm

Product Number	Maximum Torque	Weight each	Order Code KEN-557	Price/1 THB
TN14	1500Nm	6.1kg	-3620K	35480.00
TN27	2700Nm	7.3kg	-3630K	39281.00

Replacement Square Drives

Square Size	To Suit	Order Code KEN-567	Price/1 THB
1"	TN27	-9400K	NA

KENNEDY Angular Torque Gauge

The gauge has an easy to read 360° scale in 2°, 10° and 30° increments and has an Indicator etched into the clear plastic. An adjustable arm to keep the angled scale stationary, with a long and short side for flexibility in positioning against components.



Product Number	Capacity Nm	Weight each	Order Code KEN-557	Price/1 THB
TGA360	0 - 360	180g	-0150K	1187.00

Nut Spinners

Manufactured from hardened and tempered chrome vanadium steel, with satin chrome finish. Oil and acid resistant high impact plastic handles. 6" (150mm) combined socket and blade length.

Overall length: 230mm.



Type	Hexagon AF	Order Code KEN-556	Price/1 THB
Metric	4.0mm	-7400K	NA
	4.5mm	-7450K	323.00
	5.0mm	-7500K	258.00
	5.5mm	-7550K	264.00
	6.0mm	-7600K	270.00
	7.0mm	-7700K	288.00
	8.0mm	-7800K	300.00
	9.0mm	-7900K	312.00
BA	10.0mm	-8100K	318.00
	0BA (.413")	-1200K	225.00
	2BA (.324")	-1220K	233.00
	3BA (.282")	-1230K	239.00
	5BA (.220")	-1250K	256.00
	6BA (.193")	-1260K	272.00



Sets

Number of Pieces	Contents	Order Code KEN-556	Price/Set THB
7	0, 1, 2, 3, 4 & 6BA	-9520K	1523.00
9	4, 4.5, 5, 5.5, 6, 7, 8, 9 & 10mm	-9620K	2909.00

