

KOBE 13mm Reversible Pistol Drill

FPD500

Suitable for high torque drilling applications as well as screwdriving, hole sawing and cylinder honing. Rubber handle provides grip and operator comfort. 1/2" chuck. Adjustable side handle. Short gear case design. Heavy duty gearing system with oil-less bushing. Spring loaded rotor vanes. Rear exhaust. Ball bearing construction for a long tool life.



Spindle thread: 3/8" - 24.
Air inlet thread: 1/4" NPT.
Minimum air hose size (ID): 3/8" (10mm).
Air pressure: 90psi/6.2bar.
Air consumption: 3.65cfm*.
Sound pressure level: 95dBA.
Sound power level: 100dBA.
Vibration level: 0.4m/s².
Overall length: 240mm.



*Based on a 15 second cycle per minute average use.

Free Speed (rpm)	Order Code KBE-270	Price/1 THB
500	-2142K	9314.00

KOBE 13mm Heavy Duty Pistol Drill

DP513

13mm Jacobs chuck, high reduction gearbox, high torque, with side handle, 1/2hp motor.

Air inlet thread: 1/4" NPT.
Minimum hose: 3/8" (10mm)
Spindle thread: 3/8" - 24.

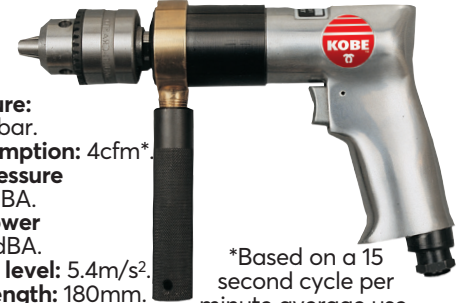

Air pressure: 90psi/6.3bar.
Air consumption: 4cfm*.
Sound pressure level: 85dBA.
Sound power level: 101dBA.
Vibration level: 5.4m/s².
Overall length: 180mm.

*Based on a 15 second cycle per minute average use.

Free Speed (rpm)	Weight each	Order Code KBE-270	Price/1 THB
500	1.80kg	-1500E	7980.00

13mm Reversible Heavy Duty Pistol Drill

DPR813

Jacobs chuck, thumb switch for reverse, auxiliary handle, suitable for screwdriving, heavy duty planetary gearing.

Air inlet thread: 1/4" NPT.
Minimum hose: 3/8" (10mm).
Spindle thread: 3/8" - 24.
Air pressure: 90psi/6.3bar.



Air consumption: 4cfm*.
Sound pressure level: 89dBA.
Sound power level: 101dBA.
Vibration level: 2.5m/s².
Overall length: 178mm.

*Based on a 15 second cycle per minute average use.

Free Speed (rpm)	Weight each	Order Code KBE-270	Price/1 THB
800	1.80kg	-1525F	8505.00

KOBE 10mm Straight Air Drill

BCSD10

Exhaust outlet adjusts 360° to direct air flow away from the operator. Keyless chuck and safety lever throttle. Ergonomic and comfortable hand grip.

Motor power: 0.45hp.
Air inlet thread: 1/4" BSP.
Operating pressure: 90psi/6.2bar.
Minimum air hose size (ID): 3/8" (10mm).
Sound pressure level: 92dBA.
Sound power level: 110dBA.
Vibration level: 0.49m/s².
Overall length: 215mm.

*Based on a 15 second cycle per minute average use.



Free Speed (rpm)	Weight each	Order Code KBE-270	Price/1 THB
2,500	1.80kg	-6050K	6195.00

13mm Reversible Pistol Grip Drill

B2842

Use for drilling and screwdriving. Two speed trigger (slow speed when pushed halfway). Directional lever accessible from both sides for left/right handed use. 13mm (1/2") chuck and detachable side handle included. Planetary gears for longer life and smoother running. Ergonomic comfortable grip.

Recommended air pressure: 6.2bar (90psi).
Air inlet thread: 1/4" NPT.
Minimum air hose size (ID): 3/8" (10mm).
Vibration level #: 0.4m/s².
Air consumption: 4cfm* (113ltr/min).
Spindle thread: 3/8" - 24.
Noise level†: 86dBA. Sound power level*: 93dBA.
Overall length: 218mm.

†Per EN ISO 15744:2002.
#Per EN 28927-5.



*Based on a 15 second cycle per minute average use.

Free Speed (rpm)	Weight each	Order Code KBE-270	Price/1 THB
800	1.30kg	-4330K	10490.00



Ergonomic comfortable grip.

Two speed trigger for slow or fast action.

Forward/Reverse lever action.

Complete with industrial chuck.