



Brazed Tip Turning & Boring Tools

Manufactured in three standard grades (all sizes are nominal).
Manufactured to ISO DIN BHMA Standards.

- P40** P40: Roughing to heavy roughing of steel and steel castings using heavy feeds and low to medium cutting speeds. Also used under unfavourable conditions, particularly where intermittent cutting is involved. This grade is also suitable for planing operations and for machining manganese steel.
- P30** P30: Carbide tipped tools are suitable for heavy duty turning and boring on all classes of steel. Suitable also for interrupted cutting and machining at low speeds and heavy feeds.
- K20** K20: General purpose tools for most applications. Ideal for machining cast iron, non-ferrous metals, bakelite etc. Combines wear resistance with toughness when rough turning at moderate cutting speeds. Suitable for high feed rates.

Straight Round Nosed Turning Tools

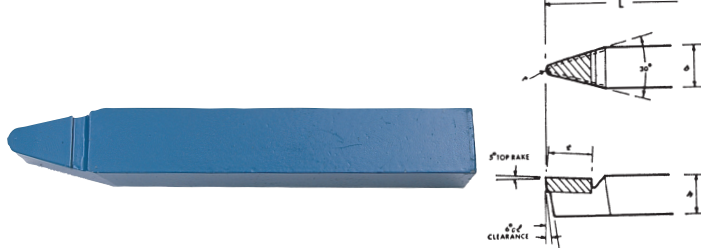

Tool No.	Cut	Shank Height x Width	Weight each	Order Code KEN-100			Price/1 THB
				P40	P30	K20	
010	N	3/8" x 3/8"	160g	-	-0100K	-	1040.00
012	N	1/2" x 1/2"	190g	-	-0140K	-0150K	1040.00
016	N	5/8" x 5/8"	240g	-	-0190K	-0200K	1323.00
020	N	3/4" x 3/4"	410g	-	-0230K	-0240K	1628.00
024	N	1" x 3/4"	520g	-	-0270K	-	1901.00
026	N	1" x 1"	760g	-	-0310K	-	2300.00

Cranked Round Nosed Turning Tools

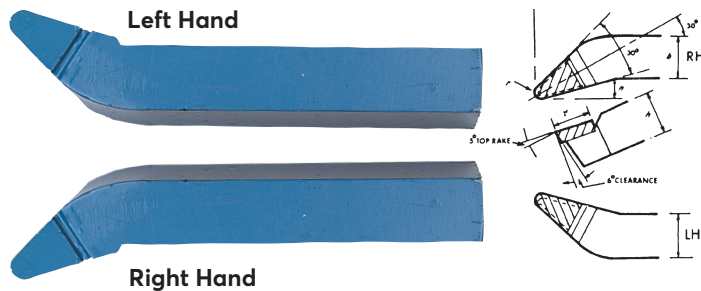

Tool No.	Cut	Shank Height x Width	Weight each	Order Code KEN-100			Price/1 THB
				P40	P30	K20	
12	RH	1/2" x 1/2"	110g	-	-0510K	-0520K	1449.00
13	LH	1/2" x 1/2"	110g	-	-0530K	-0540K	1449.00
16	RH	5/8" x 5/8"	240g	-	-0590K	-0600K	1512.00
17	LH	5/8" x 5/8"	240g	-	-0610K	-	1512.00
20	RH	3/4" x 3/4"	410g	-	-0690K	-0700K	1901.00
21	LH	3/4" x 3/4"	410g	-	-0710K	-0720K	1901.00
26	RH	1" x 1"	720g	-	-0820K	-	2237.00
27	LH	1" x 1"	720g	-	-0840K	-	2237.00

Light Turning & Boring Tools

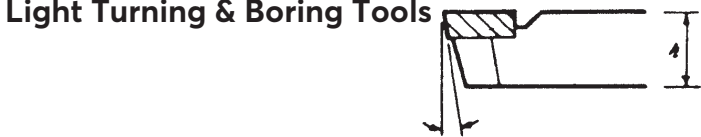

Tool No.	Cut	Shank Height x Width	Weight each	Order Code KEN-100			Price/1 THB
				P40	P30	K20	
40	N	3/8" x 3/8"	70g	-	-1000K	-	1103.00
44	N	1/2" x 1/2"	120g	-	-1060K	-1070K	1271.00
60	N	3/4" x 3/4"	430g	-	-1660K	-	1733.00

Bar Turning Tools

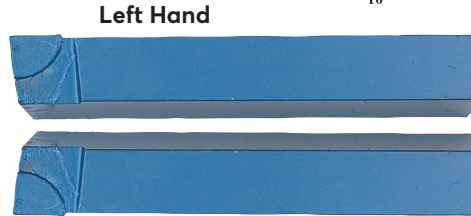
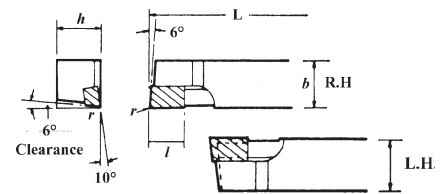

Tool No.	Cut	Shank Height x Width	Weight each	Order Code KEN-100			Price/1 THB
				P40	P30	K20	
100	RH	3/8" x 3/8"	70g	-	-2010K	-	987.00
101	LH	3/8" x 3/8"	70g	-	-2040K	-	987.00
102	RH	1/2" x 1/2"	120g	-2055K	-2060K	-2080K	1103.00
103	LH	1/2" x 1/2"	120g	-	-2100K	-2110K	1103.00
106	RH	5/8" x 5/8"	260g	-	-2180K	-	1397.00
110	RH	3/4" x 3/4"	440g	-	-2280K	-2290K	1586.00
111	LH	3/4" x 3/4"	440g	-	-2300K	-	1586.00

Bar & Knee Turning Tools

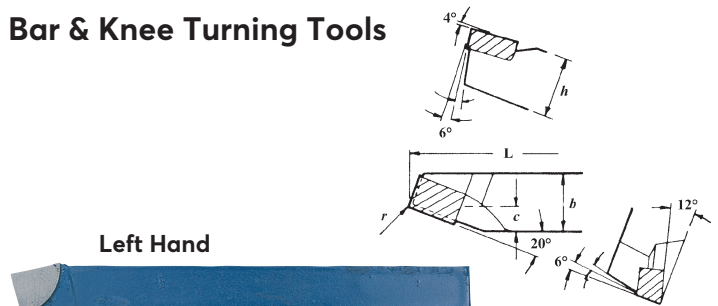

Tool No.	Cut	Shank Height x Width	Weight each	Order Code KEN-100			Price/1 THB
				P40	P30	K20	
132	RH	1/2" x 1/2"	120g	-	-2550K	-	1512.00
140	RH	3/4" x 3/4"	430g	-	-2610K	-	1617.00
141	LH	3/4" x 3/4"	430g	-	-2630K	-	1733.00

Cranked Turning Tools

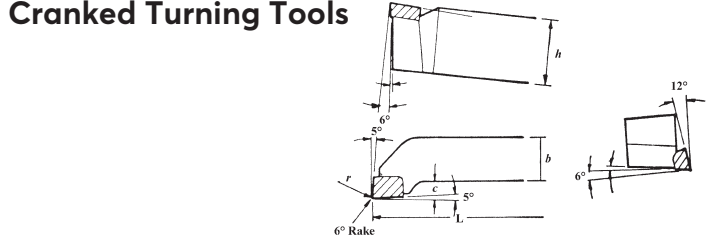

Tool No.	Cut	Shank Height x Width	Weight each	Order Code KEN-100			Price/1 THB
				P40	P30	K20	
160	RH	3/8" x 3/8"	70g	-	-2780K	-2790K	1218.00
161	LH	3/8" x 3/8"	70g	-	-2800K	-	1218.00
162	RH	1/2" x 1/2"	130g	-	-2830K	-2860K	1250.00
163	LH	1/2" x 1/2"	130g	-	-2870K	-2880K	1271.00
166	RH	5/8" x 5/8"	270g	-	-2940K	-	1512.00
167	LH	5/8" x 5/8"	270g	-	-	-2990K	1617.00
170	RH	3/4" x 3/4"	460g	-	-3040K	-3070K	1848.00
171	LH	3/4" x 3/4"	460g	-	-3080K	-3090K	1848.00